

LINE: ELECTRONIC SCALE
 MODEL: EQM-1000/2000W
 BRAND: TORREY

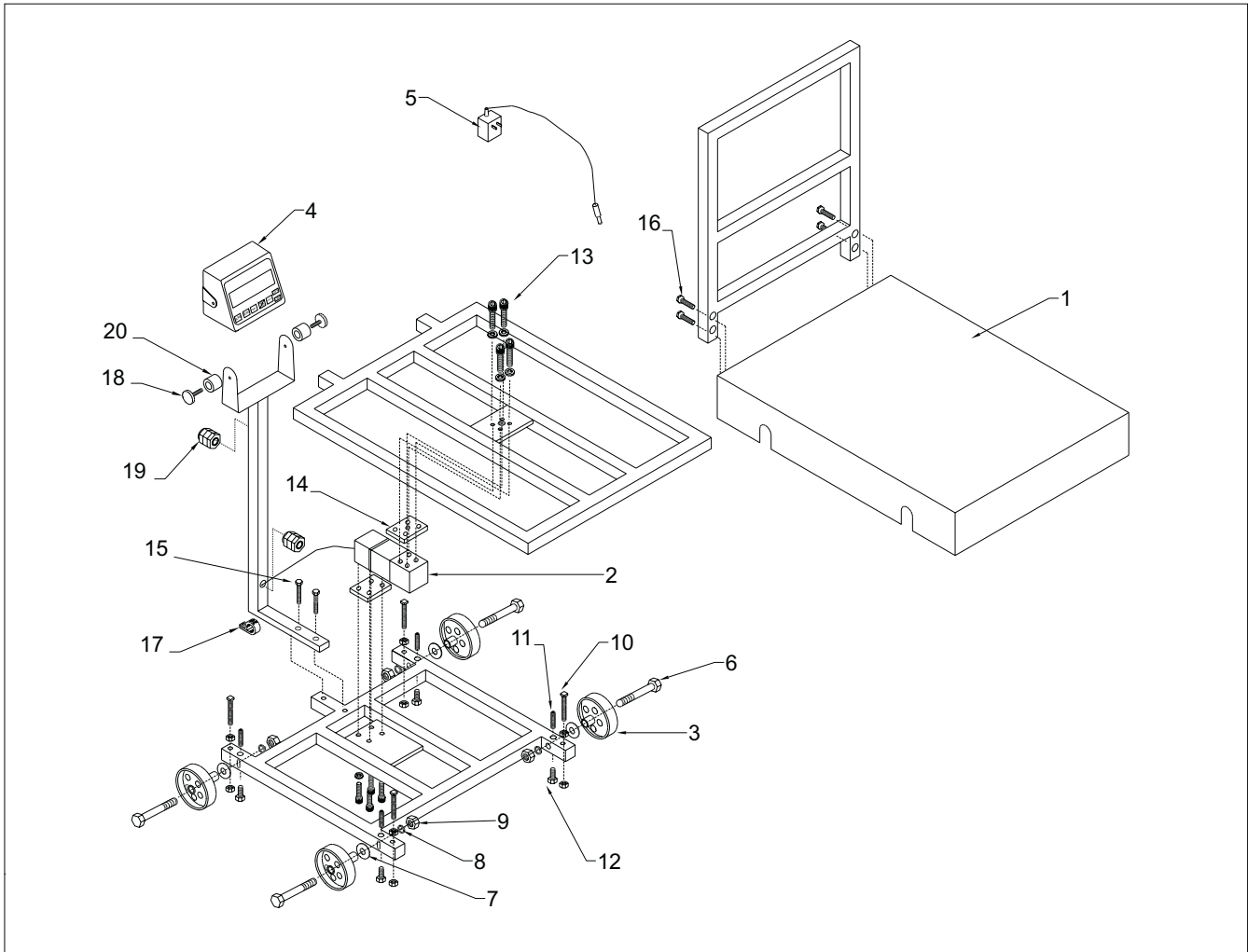

FROM THE SERIAL NUMBER:101



No.	DESCRIPTION	CODE	QTY.	R.S./100
1	EQM 1000/2000 PLATE STAINLESS STEEL	36400007	1	2
2	WEIGHT SENSOR 1000KG FOR EQM-W	46600248	1	2
3	ALUMINIUM WHEELS 5" DIAM.	56100181	4	4
4	EQB 20/40W ALUMINIUM MODULE ASSEMBLED	36500029	1	2
5	AC/DC POWER SUPPLY /STRAIGHT PLUG	21900176	1	3
6	3/4 X 5 HEX HEAD SCREW STAINLESS STEEL	56100163	4	4
7	5/8 FLAT WASHERS STAINLESS STEEL	22100067	4	4
8	5/8 HIGH STRENGTH SPRING STAINLESS STEEL	22100066	4	4
9	5/8 HEX NUT STAINLESS STEEL	22100068	4	4
10	1/2 DIAM. BOLT STUD STAINLESS STEEL	12100174	4	4
11	3/8 X 1 1/4 SETSCREW STAINLESS STEEL	22400023	4	4
12	5/8 X 1 HEX HEAD SCREW STAINLESS STEEL	12100233	4	4
13	5/16 X 1 3/4 SOCKET CAP SCREW STAINLESS STEEL	12100200	8	8
14	PLATE HOLDER STUD/ SENSOR STAINLESS STEEL	56100197	2	2
15	3/8 X 2 1/2 HEX HEAD SCREW STAINLESS STEEL	22100042	2	2
16	3/8 X 1 1/2 HEX HEAD SCREW STAINLESS STEEL	22100028	4	4
17	WIRE HARNESS CLAMP BASE 3/8 X 0.132	22400018	2	4
18	BLACK PLASTIC MODULE CLAMP	11900018	4	4
19	LIQUIT TIGHT CONNECTOR 3/8	21900107	4	4
22	BLACK NYLAMID SPREADER	34300001	4	4

R.S.= REQUIREMENT STOCK

LINE: ELECTRONIC SCALE
 MODEL: EQM 200/400W, EQM 400/800W
 EQM 1000/2000W



BRAND: TORREY FROM THE SERIAL NUMBER:
 D8860 (EQM-200/400W), D8860 (EQM-400/800W), D8495 (EQM-1000/2000W)

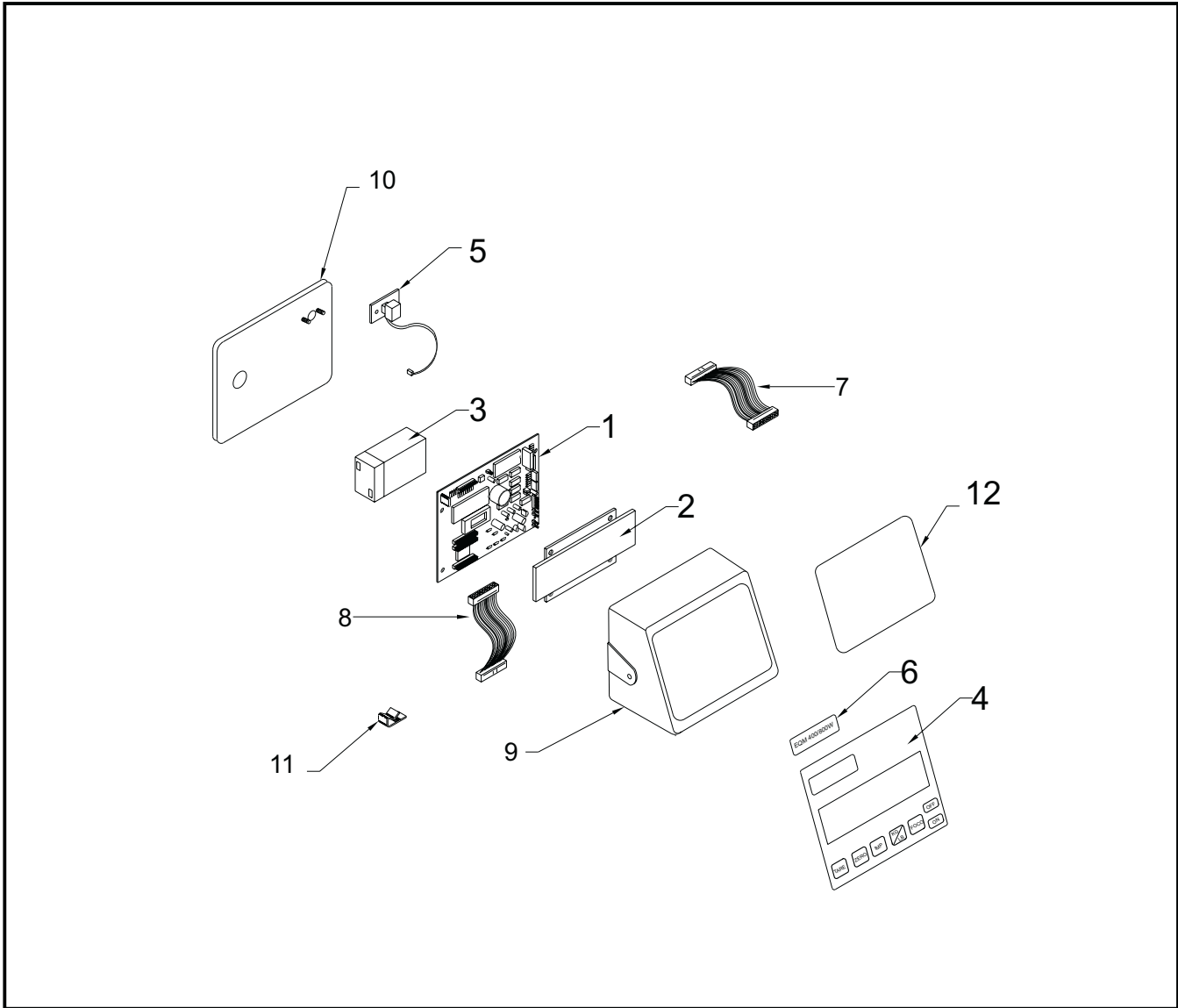

No.	DESCRIPTION	CODE	QTY.	R.S./100
1	MASTER BOARD TYPE MFQB FOR/EQM-200/400W, EQB-400/800W	46600103	1	3
1	MASTER BOARD TYPE MFQB FOR/EQM-1000/2000W	46600104	1	3
2	DISPLAY EQB/EQM W/BACKLIGHT LED	46600348	1	2
3	RECHARGEABLE BATTERY 6V	21900003	1	3
4	MEMBRANE SWITCH EQ-97	20200010	1	2
5	PLASTIC JACK ASSEMBLED	51900000	1	3
6	KEYBOARD STICKER EQM-W 200/400	13300061	1	1
6	KEYBOARD STICKER EQM-W 400/800	13300029	1	1
6	KEYBOARD STICKER EQM-W 1000/2000	13300063	1	1
7	DISPLAY 30 L/15 CM HARNESS	46600100	1	2
8	DISPLAY 30 L/30 CM HARNESS	46600101	1	2
9	ALUMINIUM MODULE EQB 20/40 W	36500029	1	1
10	CABINET COVER EQB-20/40 EQB 50/100 W	56300085	1	1
11	WIRE HARNESS CLAMP	21900001	1	2
12	4 3/4 x 7 1/4 ACRYLIC 3MM	12900049	1	1
FROM THIS SERIAL NUMBER: D8 860 (EQM-200/400W)				
D8 860 (EQM-400/800W)				
D8 495 (EQM-1000/2000W)				
2	DISPLAY EQB/EQM W/BACKLIGHT EL	46600102	1	2

R.S.= REQUIREMENT STOCK

