

No.	DESCRIPTION	CODE	QTY.	R.S./100
1	EQB-20/40 PLATE STAINLESS STEEL	36400103	1	1
2	WEIGHT SENSOR 20 KG 1041 MODEL	46600178	1	2
3	ALUMINIUM MODULE EQB-20/40-W ASSEMBLED	36500029	1	2
4	LEVELING BASE WITH NUT MF-20 STAINLESS STEEL	36700005	4	4
5	5/16 X 1 SCREW SET STAINLESS STEEL	22100058	1	2
6	OVERLOAD SUPPORT 5/16 X 2 3/8 THREAD	22200001	4	4
7	AC/DC POWER SUPPLY WITH PLUG STRAIGHT	21900176	1	3
8	1/8 PLATE HOLDER BUMPER	12400001	4	3
9	SETTING KIT 1041 -SCALE EQB	36700080	1	3
10	BLACK PLASTIC CLAMP MODULE	11900018	2	3
11	BLACK NYLAMID SPRADER	34300001	2	3
12	LIQUIT TIGHT CONNECTOR 3/8	21900107	2	3

R.S.= REQUIREMENT STOCK

LINE: ELECTRONIC SCALE  
 MODEL: EQB 20/40W, EQB 50/100W  
 BRAND: TORREY



FROM THE SERIAL NUMBER:  
 D8755 (EQB-20/40W), D81190 (EQB-50/100W)

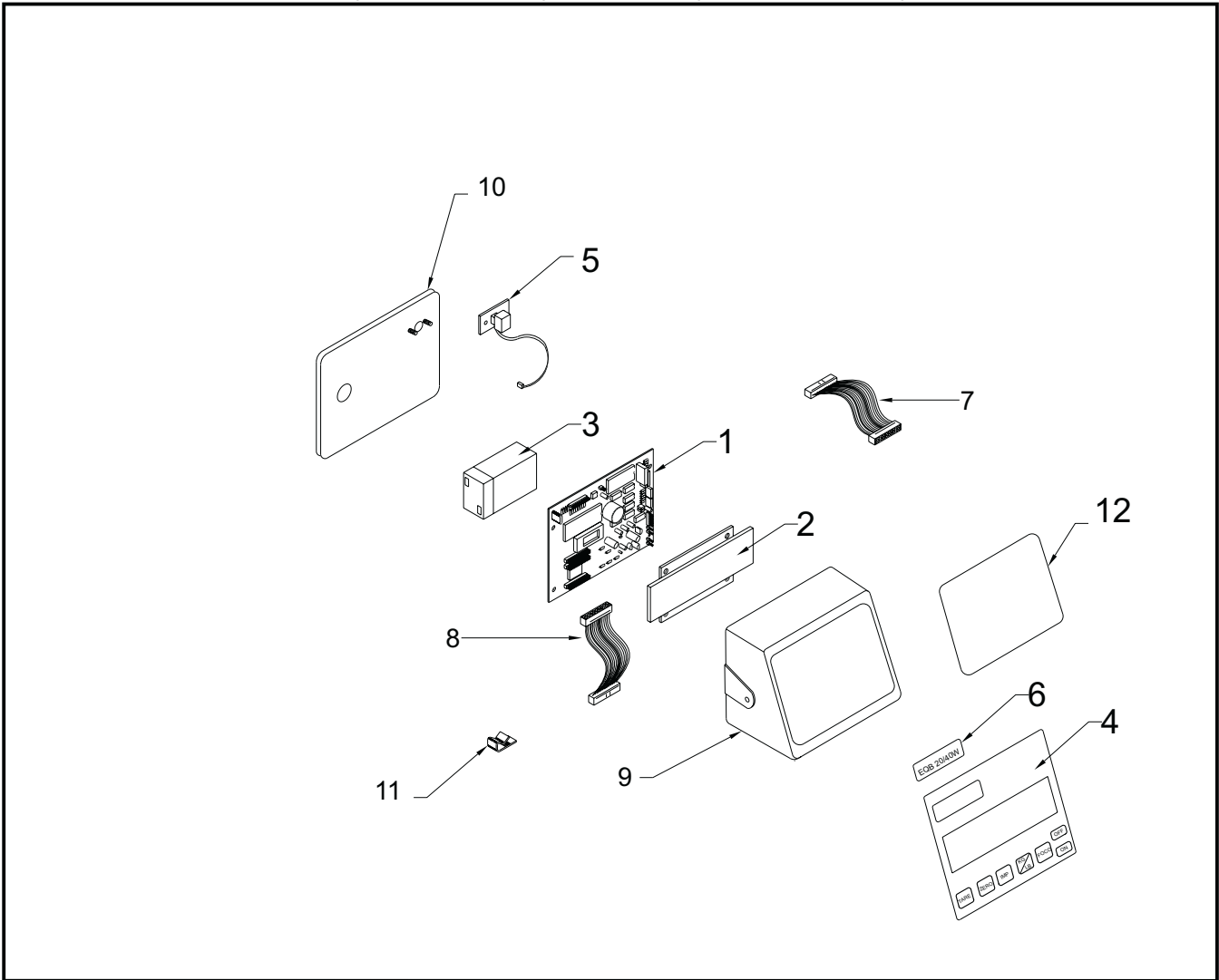

No.	DESCRIPTION	CODE	QTY.	R.S./100
1	MAESTER BOARD TYPE MFQB FOR/EQB-20/40W ASSEM.	46600109	1	3
1	MAESTER BOARD TYPE MFQB FOR/EQB-50/100W ASSEM.	46600111	1	3
2	DISPLAY EQB/EQM W/BACKLIGHT LED	46600348	1	2
3	RECHARGEABLE BATTERY 6V	21900003	1	3
4	MEMBRANE SWITCH EQ-97	20200010	1	2
5	PLASTIC JACK ASSEMBLED	51900000	1	3
6	OVERLAY EQB-20/40-W	13300027	1	1
6	OVERLAY EQB-50/100-W	13300030	1	1
7	DISPLAY 30 L/15 CM HARNESS	46600100	1	2
8	DISPLAY 30 L/30 CM HARNESS	46600101	1	2
9	ALUMINIUM MODULE 20/40 W	36500029	1	1
10	CABINET COVER EQB-20/40 EQB 50/100 W	56300085	1	1
11	WIRE HARNESS CLAMP	21900001	1	2
12	4 3/4 X 7 1/4 ACRYLIC 3MM	12900049	1	1
FROM THIS SERIAL NUMBER: D8 755 (EQB 20/40W)				
D8 1190 (EQB 50/100W)				
2	DISPLAY EQB/EQM W/BACKLIGHT EL	46600102	1	2

R.S.= REQUIREMENT STOCK

LINE: ELECTRONIC SCALE  
 MODEL: EQB-50/100W  
 BRAND: TORREY



FROM THE SERIAL NUMBER:101

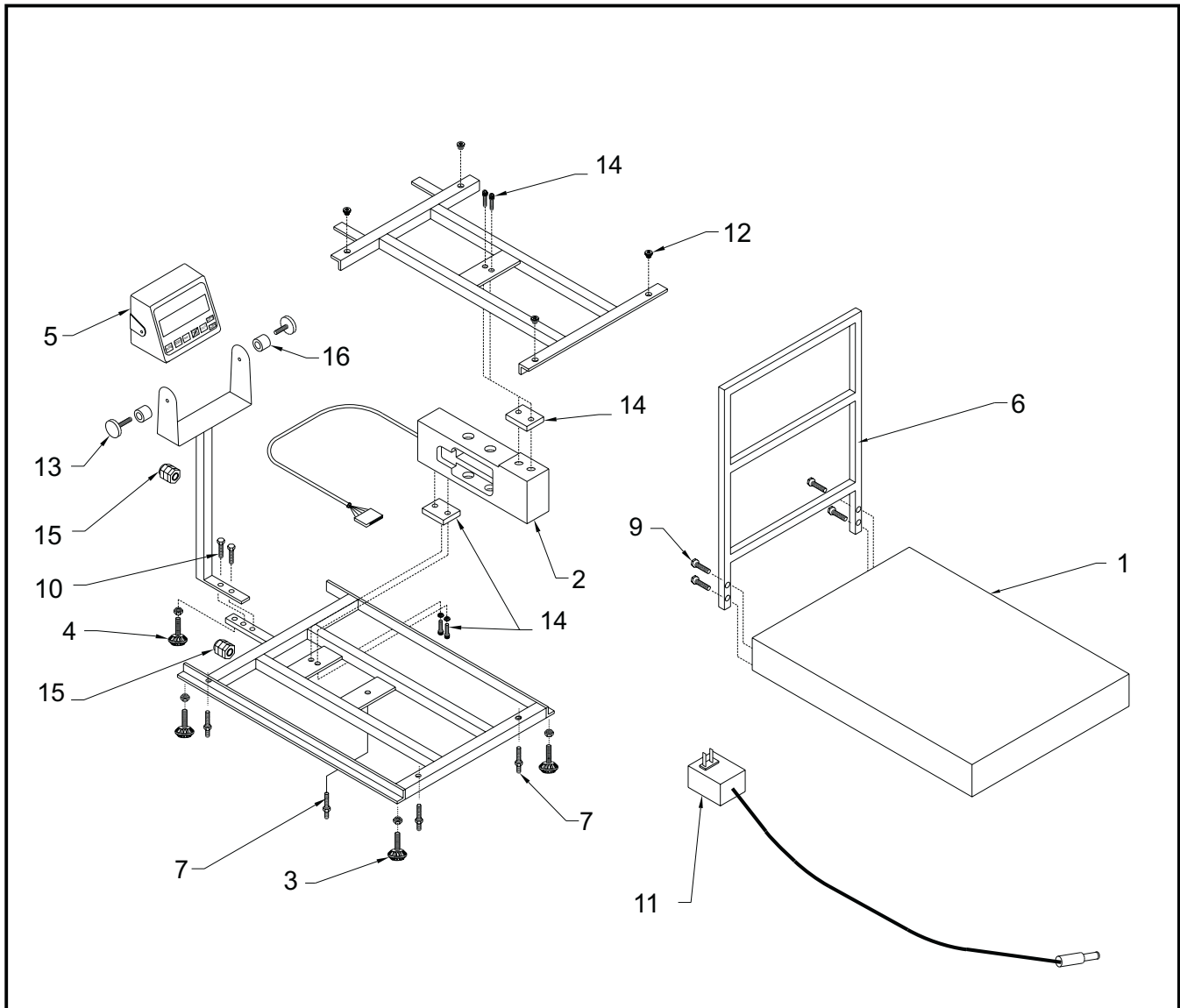

No.	DESCRIPTION	CODE	QTY.	R.S./100
1	EQB-50/100W PLATE	36400012	1	1
2	WEIGHT SENSOR 50 KG/100 LB FOR EQB-W	46600235	1	2
3	MF-20 STAINLESS STEEL LEVELING BASE INJECT	54800002	4	20
4	EQB-W STAINLESS STEEL LEVELING BASE	36700005	1	20
5	EQB-20/40-W ALUMINIUM INDICATOR ASSEMBLED	36500029	1	2
6	EQB 50/100 W PROTECTION FENCE	36400014	1	1
7	5/16 X 1 CUP POINT STAINLESS STEEL	22100058	1	1
8	5/16 x 2 3/8 OVERLOAD STUD STAINLESS STEEL	22200001	4	20
9	5/16 X 1 1/2 HEX CAP SCREW STAINLESS STEEL	22100014	4	10
10	5/16 x 3/4 SOCKET CAP SCREW STAINLESS STEEL	22100040	2	3
11	AC/DC POWER SUPPLY RIGHT PLUG	21900176	1	3
12	1/8 PLATE HOLDER BUMPER	12400001	4	3
13	BLACK PLASTIC HOLDER INDICATOR	11900018	2	3
14	FITTING KIT 1041 EQB 50/100W	36700080	1	3
15	LIQUIT TIGHT CONNECTOR 3/8	21900107	4	3
16	NYLAMID HOLDER	34300001	1	3

R.S.= REQUIREMENT STOCK